



RED-WELL-MR16-BRASS
RED-WELL-MR16-MATTE

Product Manual

Well Light

LED Landscape Light



LIFETIME
WARRANTY

www.redatomproducts.com

SPECIFICATIONS

- Solid brass construction with uniform brass/matte black finish
- High-salt, moisture and UV resistance
- High-temperature silicone o-ring for a water-tight seal
- High-temperature ceramic socket
- IP65 rated
- Works with 5 Watt and 7 Watt MR16 bulbs

INCLUDED IN THE BOX

- LED light fixture with attached 72" lead wire
- User manual

Note: Bulbs must be purchased separately. Works with MR16 bulb.

SAFETY NOTES

- Read and follow instructions: Always follow the instructions provided in this manual
- Make sure the power is turned off before installation or maintenance
- For OUTDOOR use only with low-voltage landscape lighting systems
- Fixtures are only suitable for a 12-15 Volt AC power supply
- Not intended for use with pool or spa — do not submerge in water
- Use appropriate landscape wire and outdoor rated wire nuts

WARNING: Failure to read, thoroughly understand, and follow all instructions can result in serious personal injury, damage to personal property, or voiding of factory warranty.

DIMENSIONS

- Faceplate Width: 5"
- Base width: 3.5"
- Height: 4.75"
- Faceplate/gasket/
screw base height: .75"

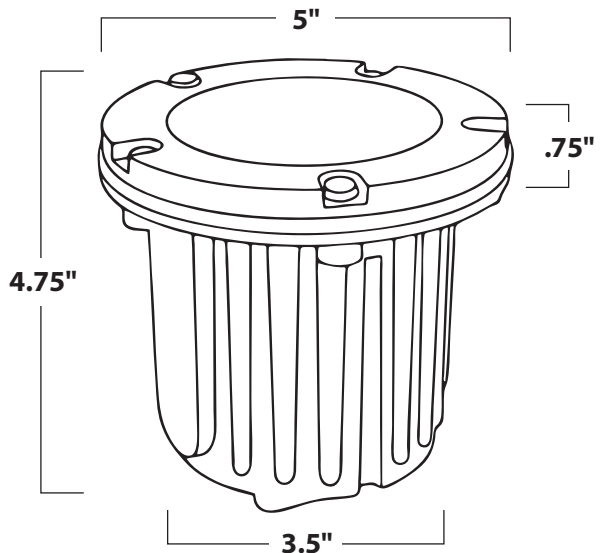

ASSEMBLY

Install the bulb

- Loosen the five lock screws and remove the faceplate and gasket
- Insert MR16 bulb and secure into place
- If needed, adjust the angle of the light by moving the swing arm assembly that holds the socket
- Reattach the gasket and faceplate, then retighten the five lock screws

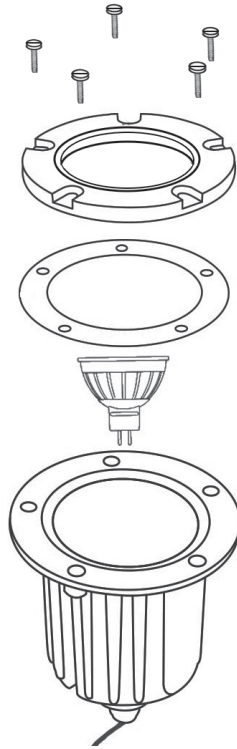

INSTALLATION INSTRUCTIONS

1. Layout fixtures at the locations where they will be installed.
2. Run landscape lighting wire from furthest point back to power supply to wire lights in a daisy chain manner. Ensure there is excess wire between each light to allow for future location adjustments.
3. Properly connect each wire to the landscape wire using outdoor rated wire nuts. The lead wire should connect to the landscape wire that came from the previous fixture and the wire that continues to the next fixture.
4. Dig a hole for the fixture that allows a few inches of space on each side as well as the bottom. Fill the hole with pea gravel to improve drainage around the fixture. Insert the fixture and ensure the faceplate is level. Finish filling the hole and pat the earth around the fixture so that it will not move.
5. Turn on the power supply and ensure every fixture is working properly.
6. Dig a small 6" deep trench and bury the landscape wiring and connectors.

TROUBLESHOOTING

Problem	Possible Cause	Solution Options
Fixture does not light up	<ol style="list-style-type: none">1. Power supply is not connected2. Bulb not installed correctly3. Wire connection is loose	<ol style="list-style-type: none">1. Check that the power supply is plugged in or receiving power. Confirm that the landscape wire is properly connected to the power supply.2. Confirm that the bulb is securely installed3. Check the connection of the landscape wire and the lead wire.
Light flickers	<ol style="list-style-type: none">1. Loose wire connection to landscape wire2. If light flickers on multiple fixtures, the wire connection to the power supply may be loose	<ol style="list-style-type: none">1. Check the connections of the landscape wire and the lead wires.2. Disconnect the power supply, confirm that the landscape wire is properly connected to the power supply.
Light is dim	<ol style="list-style-type: none">1. Maximum load of power supply has been exceeded2. Landscape wire run length has exceeded recommendation	<ol style="list-style-type: none">1. Check the total wattage of the connected lights to confirm it meets recommendations. Or, increase the power supply wattage.2. Increase the gauge size of the landscape wire.

WARRANTY

This warranty applies to US Residents who purchase from an authorized RED ATOM Dealer. RED ATOM products are covered against defects in materials and workmanship for the lifetime of the product. RED ATOM will repair or replace the defective component or product, at its sole discretion. Failure to follow product care instructions from RED ATOM will result in void of warranty. Warranty does not apply to LED bulbs. Bulbs are covered by a separate five year warranty.

Contact RED ATOM customer service at info@redatomproducts.com to obtain warranty service. You must supply a copy of your original receipt. If your product must be shipped to RED ATOM for inspection, you will be responsible for the shipping charges. Replacement product shipped to you will be returned freight pre-paid.

RED ATOM disclaims any liability for modifications, improper installations, installations over the specified power range, or failure to follow care instructions provided by RED ATOM. To the maximum extent permitted by law, RED ATOM disclaims any other warranties, expressed or implied, including warranties of fitness for a particular purpose and warranties of merchantability. RED ATOM will not be liable for any damages arising out of the use of, or inability to use, RED ATOM products.



www.redatomproducts.com